



Type: Fixed Dome - IP - Camera

Item Code: GU-CI-AC8616V

EAN CODE: 4260573063918

SMART

The SMART product line offers comprehensive coverage of modern video systems with advanced AI analysis and solutions for various application areas.

Highlights

H.265+



H.265pro+ utilizes the standard H.265/High Efficiency Video Coding (HEVC) format, but boasts advanced technologies that enable it to substantially reduce the necessary transmission bandwidth and storage capacity for maximum efficiency.

Object Classification



This technology employs a highly advanced deep learning algorithm that can discern whether the alarm was triggered by a human, a vehicle or some other object.

Smartphone App

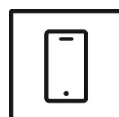

The mobile application was developed to facilitate operators in effectively controlling and managing video systems remotely, at any time. It allows for live image viewing, playback of recorded video data, and receipt of remote notifications.

Deep Learning

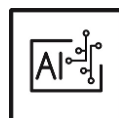

Deep Learning is inspired by the complex structure of the human brain. This innovative method allows processing of information and performing corresponding actions based on analysis.

Features

- Reduction of unwanted alarms (false alarms) by classifying target objects using deep learning algorithms. This significantly reduces false alarms generated by objects other than people or vehicles. This makes finding events easier and saves hard drive capacity
- Built-in microphone
- Many AI functions integrated such as face detection, intrusion detection, object counting, queues, heat map and much more

NDA compliant

GRUNDIG Security's SMART line is fully compliant with the National Defense Authorization Act (NDAA), which prohibits U.S. federal agencies and their partners from using video surveillance and telecommunications equipment or services from certain Chinese companies. This law is part of the John S. McCain NDAA and is effective August 2020.

With our SMART product line, you can be confident that your security system complies with this important regulation. Our products meet the highest standards of quality and reliability, providing you with the security you need to protect your assets and personnel.

Specifications GU-CI-AC8616V**Camera**

Image Sensor:	1/2.7" progressive Scan CMOS
Video Resolution:	3840 × 2160
Sensitivity Colour:	0.009 Lux @ F1.6 (AGC ON)
Sensitivity B/W:	0 Lux LED IR on
Shutter Speed:	1/5 ~ 1/20000 s
Slow Shutter:	Support
White Balance:	Auto, Manual

Lens

Lens Focal Length:	2.8 mm
Iris F-Number:	F1.6
Lens Drive Type:	Fixed Iris
Field of View:	110° (horizontal), 58° (vertical), 133° (diagonal)

Illuminator

Max. IR Distance:	Up to 20 m
-------------------	------------

Video

Col/B&W:	Auto, IR-cut filter removable (ICR)
Wide Dynamic Range:	Digital WDR
Image Enhancement:	BLC, 3D DNR, HLC
Image Settings:	Rotate mode, Saturation, Brightness, Contrast, Sharpness and white balance adjustable by client software or web browser
Day/Night Switch:	Support auto, scheduled, day, night
Privacy zones:	4 zones, rectangle

Audio

Audio Detection:	Detects unusual noises: dogs barking, babies crying, gunshots, sudden sound increase and decrease
------------------	---

Frame Rate

Main Stream:	50 Hz: 20 fps (3840 x 2160), 25 fps (2592 x 1944, 3072 x 1728, 2592 x 1520, 2304 x 1296, 1920 x 1080, 1280 x 960, 1280 x 720) 60 Hz: 20 fps (3840 x 2160), 30 fps (2592 x 1944, 3072 x 1728, 2592 x 1520, 2304 x 1296, 1920 x 1080, 1280 x 960, 1280 x 720)
Sub- Stream:	50 Hz: 25 fps (1280 × 720, 640 × 480, 640 × 360) 60 Hz: 30 fps (1280 × 720, 640 × 480, 640 × 360)
3rd Stream:	50 Hz: 25 fps (640 x 480, 320 x 240) 60 Hz: 30 fps (640 x 480, 320 x 240)

Network

Functions:	One-key reset, anti-flicker, three streams, mirror, password protection, privacy mask, IP-address filter
Video Compression:	H.264, H.264+, H.265, H.265+ , MJPEG
Bit Rate:	256 Kbps to 16 Mbps
SD Memory:	Built-in Micro SD up to 512 GB, NAS (Support NFS, SMB/CIFS)
Network Protocol:	TCP/IP, HTTP, HTTPS, FTP, DHCP, DNS, DDNS, RTP, RTSP, NTP, UPnP, SMTP, SNMP, 802.1X, IPv4/IPv6, PPPoE
Cyber Security:	Different password levels, password protection, complicated password, HTTPS encryption, digest authentication for HTTP/HTTPS , IP address filter, WSSE and digest authentication for ONVIF, RTP/RTSP over HTTPS, control timeout settings, security audit log, TLS 1.0, TLS 1.1 & TLS 1.2, TLS 1.2 with updated cipher suites including AES 256 encryption, Brute Force Delay Protection, Signed Firmware.

I/O Interface

Audio Input/Output:	Built-in microphone
Network Interface:	1x 10, 100 Base T, TX PoE (RJ-45)

Intelligent Functions

Motion Detection:	On, Off, Area Setting, Sensitivity
People & Vehicle Detection:	Adjustable whether people, motorized or non-motorized vehicles should be detected.
Intrusion Detection:	People, motorized vehicles or non-motorized vehicles, enter, exit or drive over a predefined virtual area, up to 4 rules are supported
Line Crossing:	People, motorized vehicles or non-motorized vehicles cross a pre-defined virtual line, up to 4 rules are supported
Object Removal:	Detects objects left over or lost in the pre-defined region such. In this case an alarm notification or signal will be sent automatically and in real time.
Object Counting:	Entrance and Exit object number is accounted and showed on screen in real time
Face Detection:	Human face appears in the image can be detected and trigger event action
Heat Map:	Visualizes the number of people in the surveillance area over a period of time with a simple and user-friendly color scheme
Queue Length Detection:	Counts people in a predefined area and measures service time. The area, the maximum number of people in it and the maximum service time can be set
Crowd Density Detection:	Counts people in a predefined area. The area, the maximum number of people in it can be set
Limits of intelligent functions:	Only one of the AI functions can be selected at a time
Event Source:	Video tampering, network disconnected, IP address conflicted, motion, various AI functions, sudden audio increase-decrease
Event Action:	Send e-mail, trigger alarm output, push notification for GSVM App and C-WERK, upload to FTP/Cloud, trigger HDD recording and/or image capture, show message on screen, PTZ linkage, voice prompt, buzzer

Approvals

Protection Rating:	IP67 (IEC 60529-2013), IK10 (IEC 62262:2002)
Regulation:	CE, EAC, FCC, RoHS Compliant
Standard:	ONVIF (Profile S, Profile G, Profile T, Profile M), SDK/API
MTBF at 25° C:	>60.000 hours

Environmental

Operating Temperature:	-35 °C ~ 60 °C (-31 °F ~ 140 °F)
Humidity:	Less than 95%, non condensing

Electrical

Supply Voltage:	12 VDC, PoE (IEEE 802.3af)
-----------------	----------------------------

Electrical

Power Consumption:	Max. 5 W
--------------------	----------

Mechanical

Mount:	Pan: 0° to 355°, tilt: 0° to 90°, rotate: 0° to 355°, 3-Axis Adjustment
--------	---

Dimensions:	Ø 115 × 92mm (Ø 4.5 × 3.6 inch)
-------------	---------------------------------

Weight:	520 g (1.15 lb)
---------	-----------------

Packaging

Package Dimensions:	160 x 160 x 130 mm (6.3 x 6.3 x 5.1 inch)
---------------------	---

Package Weight:	600 g (1.3 lbs)
-----------------	-----------------

Packaging Unit:	24
-----------------	----

Bulk Package Dimensions:	500 x 335 x 410 mm (19.7 x 13.2 x 16.1 inch)
--------------------------	--

Bulk Package Weight:	12200 g (26.9 lbs)
----------------------	--------------------

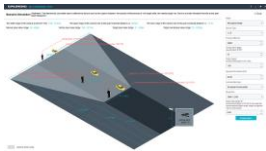
Accessories

GU-SW-INST-TOOL

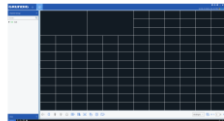

GU-SW-VMS



GU-SW-IP-FINDER

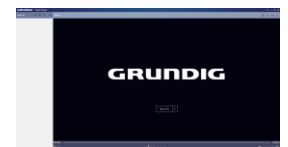

GU-SW-PLAYER



GD-HW-SD-128GB



GD-HW-SD-256GB



GU-BR-AJX09



GU-BR-AJX10



GU-BR-AMF02



GU-BR-AMW04

Dimensions

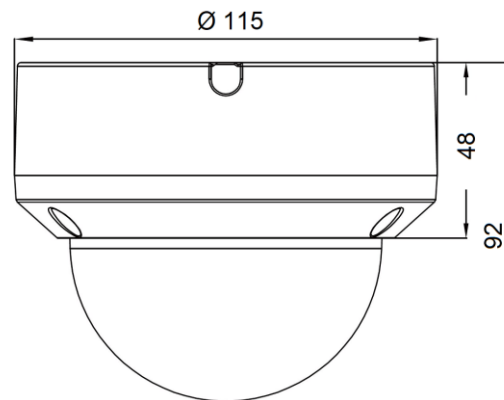

Smart Line

In addition to the usual reliability, the SMART product line from GRUNDIG Security offers numerous image analysis functions, supported by artificial intelligence (AI). For example, use the LPR function to recognize license plates or facial recognition to identify people. Or reduce the number of false alarms by classifying objects as 'Vehicle', 'Person' or 'Other'. GRUNDIG Security's SMART cameras are able to detect people in crowds, count the number of heads and measure the length of queues, e.g. B. to be determined in the checkout area. In this way, they help you to use your resources optimally. They also inform you if unauthorized people cross predefined lines or enter certain areas.

Guarantee

All cameras in the "SMART", "PRO" and "PREMIUM" product lines have an extended warranty period of 5 years on electronic parts, mechanical wear and tear on moving parts is not included. Please note our general delivery terms and conditions.

Environmentally friendly packaging

Our environmentally friendly packaging with less colour print is made from 100% recyclable material. To save resources, our detailed operating instructions are available online for download. The quick reference guides that come with the devices are printed on 100% recycled paper.