



Air2-BS200

Wireless transceiver

Wireless transceiver with I-BUS interface for connection to Inim intrusion-control panels.

The Air2-BS200/50 is capable of managing 50 terminals of the field devices (infrared, double technology, curtain detectors and magnetic contacts) and 100 wireless keyfobs (KF100 or KF-Ergo or KF-Pebble).

Air2-BS200/30 is capable of managing 30 terminals of the field devices and 50 wireless keyfobs.

Air2-BS200/10 is capable of managing 10 terminals of the field devices and 30 wireless keyfobs.

Air2-BS200 is also capable of managing up to 4 Air2-Aria/W keypads, 4 sounder/flashers (Air2-Hedera, Air2-SmartyW, Air2-DS100/W), 10 temperature sensors (Air2-SenseTH100/W), 10 home-automation modules (Air2-Flex2R/2I) and 10 foggers (InFog).

Each field device can be mapped on one of the terminals available on the control panel in the same way as each keyfob can be mapped on one of the Inim tags.



TECHNICAL SPECIFICATIONS

	BS200/10	BS200/30	BS200/50
Voltage		from 9 to 16V $\overline{=}$	
Current draw		20-50 mA	
Communication with wireless devices		Two-way	
Operating frequency		868MHz	
Programmable supervision time of wireless devices		from 12 to 250 minutes	
Connection to control panel		4 wires via the I-BUS	
Terminals	10	30	50
Wireless keys supported	30	50	100
Home-automation modules		10	
Temperature sensors		10	
Manageable sounder/flashers		4	
Manageable keypads		4	
Foggers		10	
Field devices mapping		On terminals	
Wireless key mapping in control panel		On tags and cards	
Protections		Anti-opening and anti-dislodgement	
Dimensions (HxWxD)		172x80x27 mm	
Weight		135 g	
Security grade		2	
Environmental class		II	

DIMENSIONS

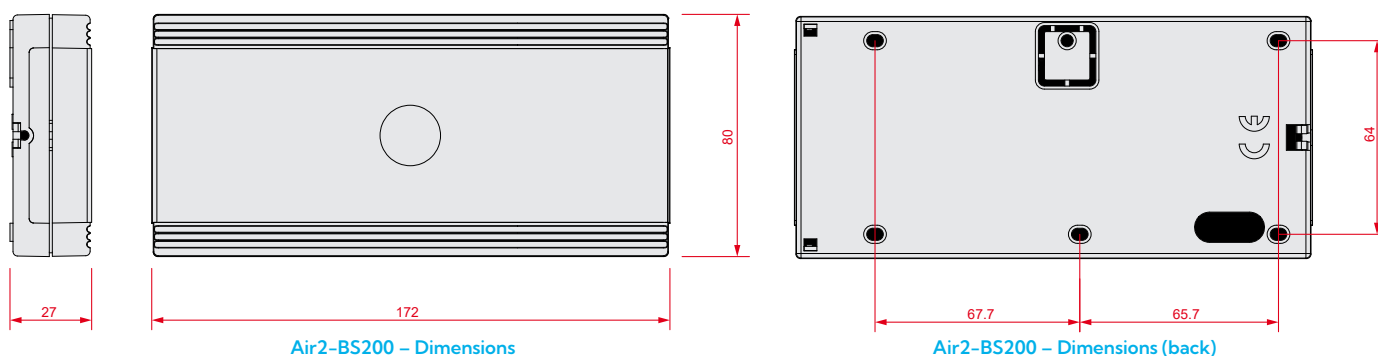

WIRING DIAGRAM

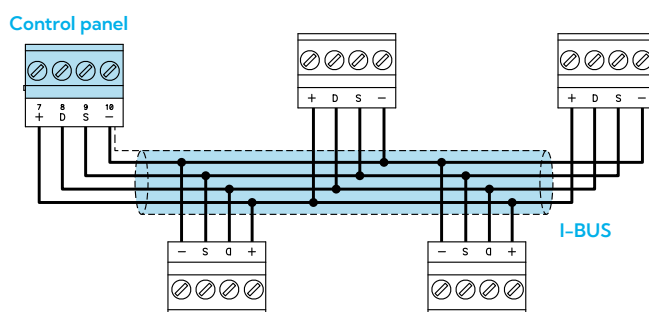

CONNECTABLE WIRELESS DEVICES

AIR2-ARIA/W	Wireless control keypad with LCD, in white
AIR2-DS100/W	Self-powered wireless sounder/flasher for outdoor installation, blue or transparent visual signaller
AIR2-ERGO	Ergonomic remote-control key, in white or black enclosure
AIR2-FD100	Wireless smoke detector
AIR2-FLEX2R/2I	Wireless home-automation expansion module with 2 relays and 2 IN terminals
AIR2-HERDERA	Wireless sounder/flasher for outdoor installation with anti-foam protection
AIR2-KF100	Remote-control key, 4 programmable keys, in black enclosure
AIR2-KFPEBBLE	Soft-touch remote-control key, 4 programmable keys, in grey, red, blue or black enclosure
AIR2-MC200/S	Wireless micro-magnetic contact with shock and tilt sensor, in white or brown enclosure
AIR2-MC300	Wireless magnetic contact with two I/O terminals, in white or brown enclosure
AIR2-MC400	Wireless micro-magnetic contact, in white or brown enclosure
AIR2-QDT200/W	Wireless microwave infrared motion detector for indoor installation
AIR2-QDT600/W	Wireless dual-technology curtain motion detector, in white or brown enclosure
AIR2-QDT900/W	Wireless dual technology perimeter detector for outdoor installation
AIR2-QIR200/W	Wireless infrared motion detector for indoor installation
AIR2-SMARTY/W	Wireless sounder for indoor installation with LED flasher
AIR2-SENSETH100/W	Wireless temperature sensor, in white enclosure
AIR2-UT100/S	Universal wireless transceiver
INFOG-C100	Fogger with 130m maximum single emission
INFOG-M300	Fogger with 300m maximum single emission
INFOG-M500	Fogger with 500m maximum single emission

ORDER CODES

AIR2-BS200/10	Wireless transceiver, up to 10 terminals, up to 30 wireless keyfobs
AIR2-BS200/30	Wireless transceiver, up to 30 terminals, up to 50 wireless keyfobs
AIR2-BS200/50	Wireless transceiver, up to 50 terminals, up to 100 wireless keyfobs
AIR2-ANT100N/8	High performance 868MHz external antenna (1.5 mt. cable)